

## Tuesday 13 October 2020 – Morning

### AS Level Chemistry A

#### H032/02 Depth in chemistry

Time allowed: 1 hour 30 minutes



**You must have:**

- the Data Sheet for Chemistry A

**You can use:**

- a scientific or graphical calculator
- an HB pencil



Please write clearly in black ink. **Do not write in the barcodes.**

Centre number

|  |  |  |  |  |
|--|--|--|--|--|
|  |  |  |  |  |
|--|--|--|--|--|

Candidate number

|  |  |  |  |
|--|--|--|--|
|  |  |  |  |
|--|--|--|--|

First name(s)

---

Last name

---

### INSTRUCTIONS

- Use black ink. You can use an HB pencil, but only for graphs and diagrams.
- Write your answer to each question in the space provided. If you need extra space use the lined pages at the end of this booklet. The question numbers must be clearly shown.
- Answer **all** the questions.
- Where appropriate, your answer should be supported with working. Marks might be given for using a correct method, even if your answer is wrong.

### INFORMATION

- The total mark for this paper is **70**.
- The marks for each question are shown in brackets [ ].
- Quality of extended response will be assessed in questions marked with an asterisk (\*).
- This document has **16** pages.

### ADVICE

- Read each question carefully before you start your answer.

Answer **all** the questions.

1 This question is about nickel and its compounds.

(a) Nickel reacts with dilute hydrochloric acid in a redox reaction.



Explain, in terms of the number of electrons transferred, whether nickel is oxidised or reduced.

.....  
 .....  
 ..... [1]

(b) A student completely reacts 0.192 g of nickel with 0.150 mol dm<sup>-3</sup> HCl(aq).

(i) Calculate the minimum volume, in cm<sup>3</sup>, of 0.150 mol dm<sup>-3</sup> HCl(aq) that the student needs for the reaction.

Give your answer to **3** significant figures.

minimum volume of HCl(aq) = ..... cm<sup>3</sup> [3]

(ii) Calculate the volume of H<sub>2</sub>(g), in cm<sup>3</sup>, that would be produced at RTP.

volume of H<sub>2</sub>(g) = ..... cm<sup>3</sup> [1]

(iii) The student repeats the experiment with 0.192 g of magnesium instead of nickel, using the same volume of 0.150 mol dm<sup>-3</sup> HCl(aq) as in (b)(i).

State and explain whether the volume of H<sub>2</sub>(g) produced would be greater than, smaller than, or the same as, the value you have calculated in (b)(ii).

.....  
 .....  
 .....  
 ..... [2]

(c)\* A student is provided with samples of three nickel compounds.

One sample is nickel(II) bromide, another is nickel(II) sulfate and the third is nickel(II) carbonate. The student doesn't know which sample is which.

Describe the tests that the student could carry out to identify the anion (negative ion) in each sample, and write equations for any reactions. **[6]**

.....

.....

.....

.....

.....

.....

.....

.....

.....

.....

.....

.....

.....

.....

.....

.....

.....

.....

.....

.....

.....

.....

Additional answer space if required

.....

.....

.....

.....

.....

.....

.....

.....

.....

.....

2 Enthalpy changes of combustion can be determined directly by experiment.

(a) Explain the term **enthalpy change of combustion**,  $\Delta_c H$ .

.....

.....

.....

..... [2]

(b) A student carries out an experiment to determine the enthalpy change of combustion of cyclohexane,  $C_6H_{12}$ , using the apparatus shown in the diagram.

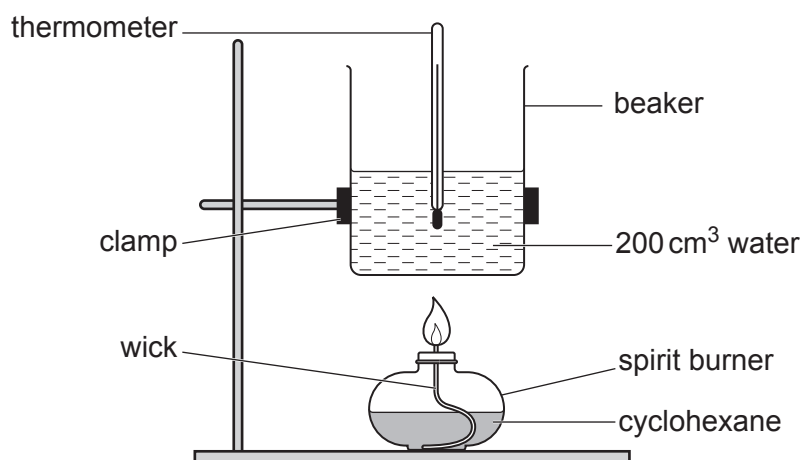

In the experiment, 0.525 g of cyclohexane are burnt, and the temperature of the 200 cm<sup>3</sup> of water changes from 21.0 °C to 41.0 °C.

Calculate the enthalpy change of combustion,  $\Delta_c H$ , of cyclohexane in kJ mol<sup>-1</sup>.

Give your answer to **3** significant figures.

$\Delta_c H = \dots\dots\dots$  kJ mol<sup>-1</sup> [4]

- (c) The student finds that their experimental value for  $\Delta_c H$  is less exothermic than the value in a data book.

The student evaluates the experimental results.

- (i) The uncertainty in each thermometer reading is  $\pm 0.5^\circ\text{C}$  and the uncertainty in the measured volume of water is  $\pm 2\text{ cm}^3$ .

Determine whether the temperature **change** or the measured volume of water has the greater percentage uncertainty.

[2]

- (ii) Suggest **two** reasons, apart from measurement uncertainties, why the experimental value for  $\Delta_c H$  is less exothermic than the data book value.

Reason 1 .....

.....

Reason 2 .....

.....

[2]

- (iii) In the experiment the water in the beaker was heated for 5 minutes. The student thought that the experiment could be improved by heating the water for 10 minutes.

Explain whether the accuracy in the student's calculated value for  $\Delta_c H$  may or may **not** be improved by heating for longer.

.....

.....

.....

.....

..... [2]



(b) Calcium reacts with bromine to form calcium bromide,  $\text{CaBr}_2$ .

(i) Draw a 'dot-and-cross' diagram to show the bonding in  $\text{CaBr}_2$ .

Show **outer** electrons only.

[2]

(ii) The reaction of barium with bromine is more vigorous than the reaction of calcium with bromine.

Explain why.

.....

.....

.....

.....

.....

.....

..... [3]

- (c) The Period 4 element selenium is in the same group of the periodic table as oxygen.

Selenium and oxygen both form compounds with hydrogen with the formulae  $\text{H}_2\text{Se}$  and  $\text{H}_2\text{O}$  respectively.

- (i)  $\text{H}_2\text{Se}$  can be prepared by reacting aluminium selenide,  $\text{Al}_2\text{Se}_3$ , with water. Aluminium hydroxide and hydrogen selenide are formed.

Write the equation for this reaction.

..... [1]

- (ii) The boiling points of  $\text{H}_2\text{O}$  and  $\text{H}_2\text{Se}$  are shown below.

| Compound              | Boiling point / °C |
|-----------------------|--------------------|
| $\text{H}_2\text{O}$  | 100                |
| $\text{H}_2\text{Se}$ | -41                |

Explain why  $\text{H}_2\text{O}$  has a higher boiling point than  $\text{H}_2\text{Se}$ .

.....  
 .....  
 .....  
 .....  
 ..... [3]

- (d) Bromine reacts with concentrated sodium hydroxide at  $50^\circ\text{C}$  as in the equation below.



- (i) Write the systematic name for  $\text{NaBrO}_3$ .

..... [1]

- (ii) This reaction is an example of disproportionation.

Use oxidation numbers to explain why. Include the meaning of the term **disproportionation**.

.....  
 .....  
 .....  
 ..... [3]



**BLANK PAGE**

**PLEASE DO NOT WRITE ON THIS PAGE**

4 Nitrosyl chloride,  $\text{NOCl}$ , is used in the industrial manufacture of nylon.

(a) The 'dot-and-cross' diagram for nitrosyl chloride is shown below.

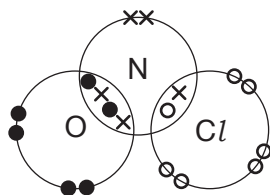

Predict the  $\text{O}=\text{N}-\text{Cl}$  bond angle and explain why  $\text{NOCl}$  has this bond angle.

Bond angle .....

Explanation .....

.....  
 .....  
 .....  
 .....  
 ..... [3]

(b) Nitrosyl chloride,  $\text{NOCl}$ , dissociates into nitrogen monoxide and chlorine as in the equilibrium below.



Nitrosyl chloride is added to a container, which is then sealed.

The container is heated to  $400^\circ\text{C}$ , and equilibrium is allowed to be reached.

(i) Write the expression for the equilibrium constant,  $K_c$ , for this equilibrium.

[1]

(ii) In the equilibrium mixture at  $400^\circ\text{C}$ , the equilibrium concentration of  $\text{Cl}_2(\text{g})$  is found to be  $0.17 \text{ mol dm}^{-3}$ .

The student calculates that the equilibrium concentration of  $\text{NO}(\text{g})$  is  $0.34 \text{ mol dm}^{-3}$ .

Explain how the student obtained this value for  $[\text{NO}(\text{g})]$ .

.....  
 .....  
 ..... [1]

- (iii) At 400 °C,  $K_c = 0.015 \text{ mol dm}^{-3}$ .

Calculate the equilibrium concentration of  $\text{NOCl(g)}$  at 400 °C.

equilibrium concentration of  $\text{NOCl(g)} = \dots\dots\dots \text{ mol dm}^{-3}$  [2]

- (iv) The temperature of the equilibrium mixture is increased above 400 °C while keeping the pressure constant.

State and explain the effect on the equilibrium concentration of nitrogen monoxide,  $\text{NO(g)}$ , with these new conditions.

.....  
.....  
.....  
..... [2]

5 This question is about the alcohols **A–F** shown below.

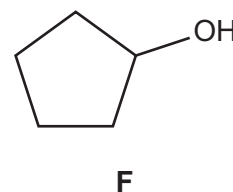
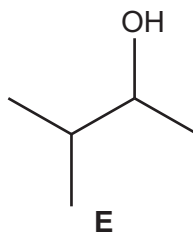
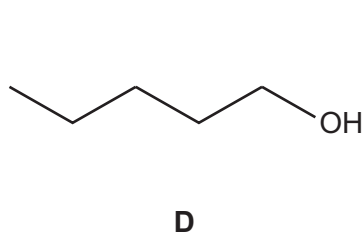
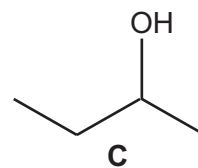
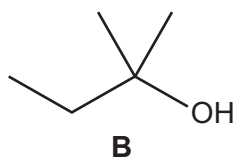
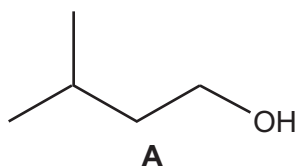

(a) Which of the alcohols **A–F** are secondary alcohols?

..... [2]

(b) Complete a balanced equation for the complete combustion of alcohol **C**.

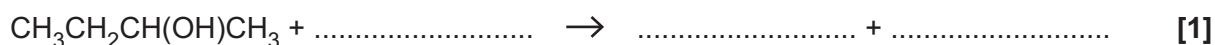

(c) What is the systematic name of alcohol **B**?

..... [1]

(d) Alcohol **A** can be prepared by the alkaline hydrolysis of the bromoalkane,  $(\text{CH}_3)_2\text{CHCH}_2\text{CH}_2\text{Br}$ . The hydrolysis with aqueous NaOH is shown in **equation 5.1**.

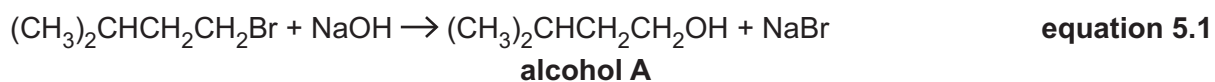

A student gently heats a mixture of  $(\text{CH}_3)_2\text{CHCH}_2\text{CH}_2\text{Br}$  and NaOH(aq) for 25 minutes.

(i) Calculate the atom economy for the preparation of alcohol **A** in **equation 5.1**.

atom economy = ..... % [2]

- (ii) Outline the mechanism for the alkaline hydrolysis of  $(\text{CH}_3)_2\text{CHCH}_2\text{CH}_2\text{Br}$ . The structure of  $(\text{CH}_3)_2\text{CHCH}_2\text{CH}_2\text{Br}$  has been provided.

Show curly arrows, relevant lone pairs and dipoles, and the products.

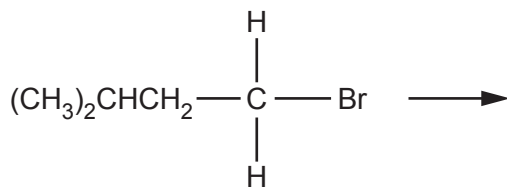

[3]

- (iii) Name this type of mechanism.

..... [1]

- (e) The student decides to prepare alcohol **A** using the same method as in (d) but using the chloroalkane  $(\text{CH}_3)_2\text{CHCH}_2\text{CH}_2\text{Cl}$  instead of the bromoalkane,  $(\text{CH}_3)_2\text{CHCH}_2\text{CH}_2\text{Br}$ .

State and explain how the rates of hydrolysis of the chloroalkane and the bromoalkane would differ.

.....

.....

.....

.....

.....

..... [2]

(f)\* The structures of **A–F** are repeated below.

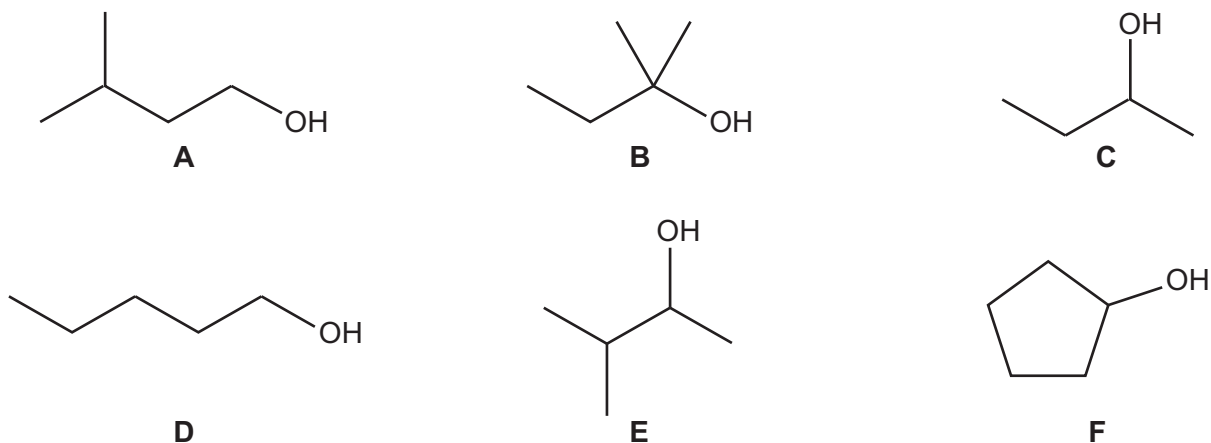

Compound **X** is one of the alcohols **A–F**.

A student refluxes compound **X** with acidified potassium dichromate(VI) as an oxidising agent. A pure sample of the organic product **Y** is obtained from the resulting mixture.

The mass spectrum and IR spectrum of **Y** are shown below.

#### Mass spectrum of **Y**

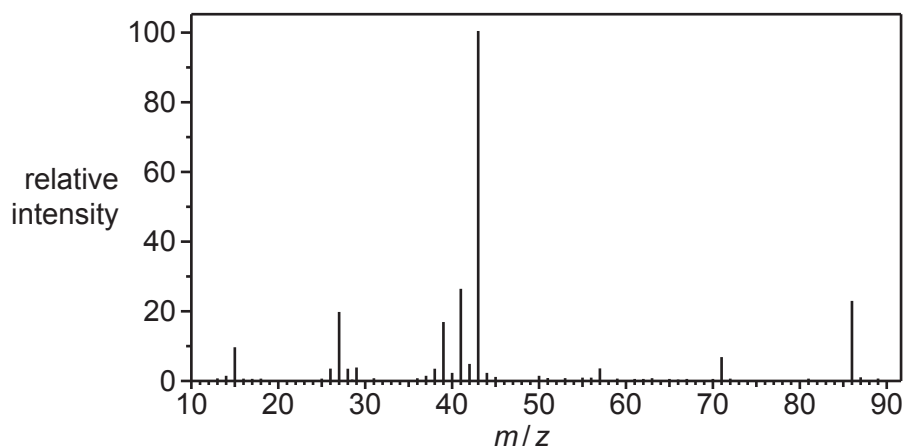

#### IR spectrum of **Y**

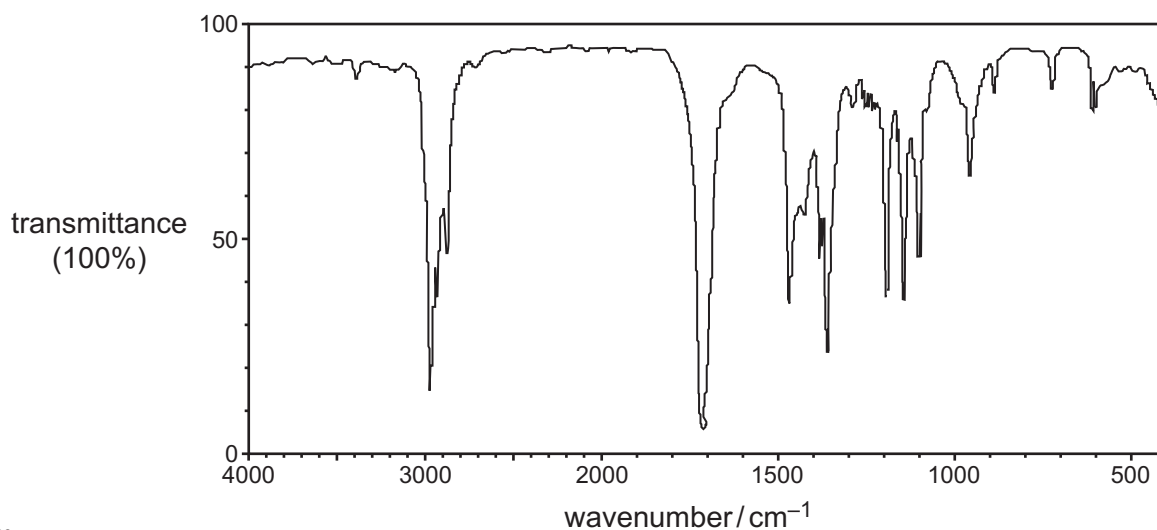

Using this information, identify compound **X** and product **Y**, and write an equation for the formation of product **Y** from compound **X**. You may use [O] to represent the oxidising agent.

In your answer you should make clear how your conclusions are linked to the evidence. **[6]**

.....

.....

.....

.....

.....

.....

.....

.....

.....

.....

.....

.....

.....

.....

.....

.....

.....

.....

.....

.....

.....

.....

Additional answer space if required

.....

.....

.....

.....

.....

.....

.....

.....

.....

.....

.....

.....

.....

.....

.....

.....

.....

.....

.....

.....

.....

.....

**ADDITIONAL ANSWER SPACE**

If additional space is required, you should use the following lined page(s). The question number(s) must be clearly shown in the margin(s).

A large rectangular area with a solid vertical line on the left side and horizontal dotted lines across the rest of the page, providing space for writing answers.



**Copyright Information**

OCR is committed to seeking permission to reproduce all third-party content that it uses in its assessment materials. OCR has attempted to identify and contact all copyright holders whose work is used in this paper. To avoid the issue of disclosure of answer-related information to candidates, all copyright acknowledgements are reproduced in the OCR Copyright Acknowledgements Booklet. This is produced for each series of examinations and is freely available to download from our public website ([www.ocr.org.uk](http://www.ocr.org.uk)) after the live examination series. If OCR has unwittingly failed to correctly acknowledge or clear any third-party content in this assessment material, OCR will be happy to correct its mistake at the earliest possible opportunity.

For queries or further information please contact The OCR Copyright Team, The Triangle Building, Shaftesbury Road, Cambridge CB2 8EA.

OCR is part of the Cambridge Assessment Group; Cambridge Assessment is the brand name of University of Cambridge Local Examinations Syndicate (UCLES), which is itself a department of the University of Cambridge.